

HB

中华人民共和国航空工业部部标准

HB3899-86

普通螺纹校对塞规

M1×0.2~M5 校通-止TZ 校通-损TS

1986-12-30发布

1987-10-01实施

中华人民共和国航空工业部 批准

普通螺纹校对塞规
 校通—止 TZ 校通—通 TS
 M1×0.2~M5

代替

其余 $\nabla 3.2$

$d=1\sim 1.6\text{ mm}$
 $P=0.2\text{ mm}$

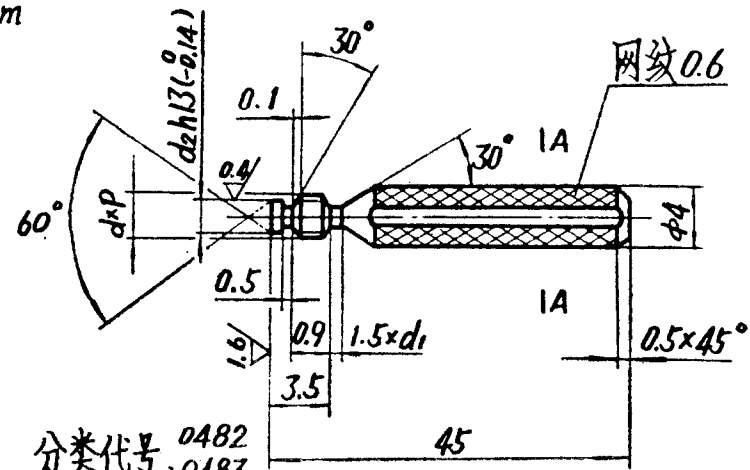

分类代号: 0482
 0483

标记示例: M1×0.2-5g6g、6g TZ 的螺纹校对塞规 0482/M1×0.2-5g、6g-TZ
 0483/M1×0.2-5g、6g-TS

螺 纹					TZ						TS			
直径 d	螺距 P	公差带	d_1	d_2 (h_{13})	大 径		中 径		小 径 \leq	大 径		中 径		小 径 \leq
					基本尺寸	极限偏差	基本尺寸	极限偏差		基本尺寸	极限偏差	基本尺寸	极限偏差	
1	0.2	3h4h 4h 5h6h 6h	0.6	0.7	0.918	± 0.003	0.878	± 0.003	0.779	0.924	± 0.003	0.884	± 0.003	0.779
		5g6g 6g			0.901	± 0.003	0.861	± 0.003	0.762	0.907	± 0.003	0.867	± 0.003	0.762
1.1	0.2	3h4h 4h 5h6h 6h	0.7	0.8	1.018	± 0.003	0.978	± 0.003	0.879	1.024	± 0.003	0.984	± 0.003	0.879
		5g6g 6g			1.001	± 0.003	0.961	± 0.003	0.862	1.007	± 0.003	0.967	± 0.003	0.862
1.2	0.2	3h4h 4h 5h6h 6h	0.8	0.9	1.118	± 0.003	1.078	± 0.003	0.979	1.124	± 0.003	1.084	± 0.003	0.979
		5g6g 6g			1.101	± 0.003	1.061	± 0.003	0.962	1.107	± 0.003	1.067	± 0.003	0.962
1.4	0.2	3h4h 4h 5h6h 6h	1	1.1	1.318	± 0.003	1.278	± 0.003	1.179	1.324	± 0.003	1.284	± 0.003	1.179
		5g6g 6g			1.301	± 0.003	1.261	± 0.003	1.162	1.307	± 0.003	1.267	± 0.003	1.162
1.6	0.2	3h4h 4h 5h6h 6h	1.2	1.3	1.518	± 0.003	1.478	± 0.003	1.379	1.524	± 0.003	1.484	± 0.003	1.379
		5g6g 6g			1.501	± 0.003	1.461	± 0.003	1.362	1.507	± 0.003	1.467	± 0.003	1.362

1. 材料: CrMn 钢, 按 GB1299-77.
2. 热处理: 淬火 HRC53~60.

3. 网纹滚花按 JB2-59.
4. 技术条件按 HB3908-86

普通螺纹校对塞规

校通—止 TZ 校通—损 TS

M1 M1.1 M1.2

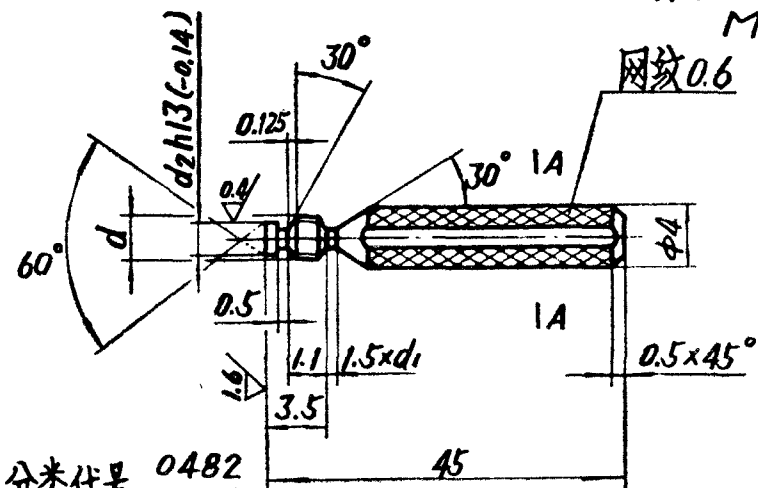

A-A

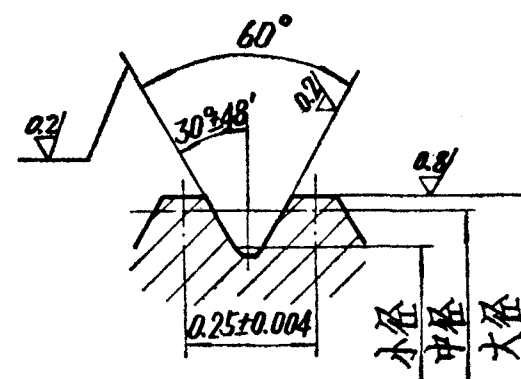
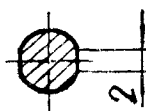

其余 ∇ 3.2

分类代号: 0482
0483

标记示例: M1-6h TZ 的螺纹校对塞规 0482 / M1-6h-TZ
0483 / M1-6h-TS

直径 d	螺距 P	公差带	d ₁	d ₂ (h13)	TZ			TS						
					大 径		中 径	大 径		中 径	小 径			
					基本尺寸	极限偏差	基本尺寸	极限偏差	基本尺寸	极限偏差	基本尺寸	极限偏差		
1		3h4h 4h 5h4h 5h6h	0.5	0.6	0.896	±0.003	0.846	±0.003	0.725	0.902	±0.003	0.852	±0.003	0.725
		6h			0.895	±0.0035	0.845	±0.0035	0.724		±0.0035	0.852	±0.0035	0.724
		5g6g			0.878	±0.003	0.828	±0.003	0.707		±0.003	0.834	±0.003	0.707
		6g			0.877	±0.0035	0.827	±0.0035	0.706		±0.0035	0.834	±0.0035	0.706
1.1	0.25	3h4h 4h 5h4h 5h6h	0.6	0.7	0.996	±0.003	0.946	±0.003	0.825	1.002	±0.003	0.952	±0.003	0.825
		6h			0.995	±0.0035	0.945	±0.0035	0.824		±0.0035	0.952	±0.0035	0.824
		5g6g			0.978	±0.003	0.928	±0.003	0.807		±0.003	0.934	±0.003	0.807
		6g			0.977	±0.0035	0.927	±0.0035	0.806		±0.0035	0.934	±0.0035	0.806
1.2		3h4h 4h 5h4h 5h6h	0.7	0.8	1.096	±0.003	1.046	±0.003	0.925	1.102	±0.003	1.052	±0.003	0.925
		6h			1.095	±0.0035	1.045	±0.0035	0.924		±0.0035	1.052	±0.0035	0.924
		5g6g			1.078	±0.003	1.028	±0.003	0.907		±0.003	1.034	±0.003	0.907
		6g			1.077	±0.0035	1.027	±0.0035	0.906		±0.0035	1.034	±0.0035	0.906

1. 材料: CrMn 钢, 按 GB1299-77。
2. 热处理: 淬火 HRC 53~60。
3. 网纹滚花按 JB2-59。
4. 技术条件按 HB3908-86